

Industrial Ethernet Extender

IVC-2002

User's Manual

Trademarks

Copyright © PLANET Technology Corp. 2011

Contents subject to revision without prior notice.

PLANET is a registered trademark of PLANET Technology Corp. The information in this manual is subject to change without notice. All other trademarks belong to their respective owners.

Disclaimer

PLANET Technology does not warrant that the hardware will work properly in all environments and applications, and makes no warranty and representation, either implied or expressed, with respect to the quality, performance, merchantability, or fitness for a particular purpose.

PLANET has made every effort to ensure that this User's Manual is accurate; PLANET disclaims liability for any inaccuracies or omissions that may have occurred.

Information in this User's Manual is subject to change without notice and does not represent a commitment on the part of PLANET. PLANET assumes no responsibility for any inaccuracies that may be contained in this User's Manual. PLANET makes no commitment to update or keep current the information in this User's Manual, and reserves the right to make improvements to this User's Manual and/or to the products described in this User's Manual, at any time without notice.

If you find information in this manual that is incorrect, misleading, or incomplete, we would appreciate your comments and suggestions.

FCC Warning

This equipment has been tested and found to comply with the regulations for a Class A digital device, pursuant to Part 15 of the FCC Rules. These limits are designed to provide reasonable protection against harmful interference when the equipment is operated in a commercial environment. This equipment generates, uses, and can radiate radio frequency energy and, if not installed and used in accordance with this user's guide, may cause harmful interference to radio communications. Operation of this equipment in a residential area is likely to cause harmful interference, in which case the user will be required to correct the interference at his own expense.

CE Mark Warning

This is a Class A product. In a domestic environment, this product may cause radio interference, in which case the user may be required to take adequate measures.

WEEE Warning



To avoid the potential effects on the environment and human health as a result of the presence of hazardous substances in electrical and electronic equipment, end users of electrical and electronic equipment should understand the meaning of the crossed-out wheeled bin symbol. Do not dispose of WEEE as unsorted municipal waste and have to collect such WEEE separately.

Revision

Industrial Ethernet Extender User's Manual

For Model: IVC-2002

Rev 1.1 (January, 2011)

Part No.: 2350-AH0340-001

Table Of Contents

1. Introduction	5
1.1 Checklist	5
1.2 Ethernet over VDSL2 Bridge Description	6
1.3 Key Features	7
1.4 Specifications	8
2. Hardware Description.....	11
2.1 Front Panel	11
2.1.1 LED indicators for IVC-2002	12
2.1.2 MODE DIP Switch	13
2.2 The Upper Panel	14
3. Installation	15
3.1 Install Industrial Ethernet Extender – IVC-2002.....	15
3.2 IVC-2002 BNC / RJ-11 Proper Connection.....	16
3.3 IVC-2002 Application Connection	17
3.4 Wiring the Power Inputs.....	19
3.5 Wiring the Fault Alarm Contact	20
3.6 Mounting Installation	21
3.6.1 Install DIN-Rail Mounting	21
3.6.2 Wall Mount Plate Mounting	22
4. Troubleshooting	24
5. FAQ.....	25

1. Introduction

1.1 Checklist

Check the contents of your package for following parts:

- IVC-2002 Industrial Ethernet Extender x 1
- DIN Rail Kit
- Wall Mount Kit
- User's Manual x 1

If any of these items are missing or damaged, please contact your dealer immediately, if possible, retain the carton including the original packing material, and use them against to repack the product in case there is a need to return it to us for repair.

1.2 Ethernet over VDSL2 Bridge Description

PLANET's state-of-the-art Ethernet-over-VDSL2 products are based on two core networking technologies: **Ethernet** and **VDSL2 (Very-high-data-rate Digital Subscriber Line 2)**. This technology offers the absolute fastest possible data transmission speeds over existing copper telephone lines or coaxial cables without the need for rewiring.

The IVC-2002 Industrial Ethernet Extender has a switching architecture with 4 RJ-45 10/100Mbps Ethernet port and one asymmetric or symmetric Ethernet over VDSL port (Asymmetric means upstream and downstream rate are not the same and Symmetric means upstream and downstream rate are similar) – the VDSL port can be RJ-11 or BNC Connector. The IVC-2002 can set to **Master** or **Slave** mode via a DIP switch. When IVC-2002 (RJ-11) is connected with other IVC-2002 device, the performance will up to 99/63Mbps for asymmetric data rate within 200m and up to 28/2Mbps at 1.4km. The IVC-2002 (BNC) performance is up to 99/65Mbps for asymmetric data rate within 200m and up to 31/4Mbps at 2.4km. This capability is ideal for use as an Ethernet extender for your existing Ethernet network.

The IVC-2002 Industrial Ethernet Extender with slim type of IP-30 metal shape for easily deployment in Heavy Industrial demanding environments.

PLANET Industrial Ethernet Extender provides a lower cost replacement and smooth migration for existing **Long Reach Ethernet (LRE)** networks.

The cable specifications of the connection are listed as following:

- 10Base-T, Category 3, 4 or 5 UTP
- 100Base-TX, Category 5, 5e or 6 UTP
- Ethernet over VDSL2, Twisted-pair Telephone Wires
- Ethernet over VDSL2, Coaxial Cable



Note

Slave device (CPE) must connect to Master device (CO) through the telephone wire or coaxial cable. It is not allow connecting like Master to Master or Slave to Slave. To define the IVC-2002 to Master or Slave, please refer to section 2.1.2 for more detail.

1.3 Key Features

The Industrial Ethernet Extender provides the following key features:

- Cost-effective VDSL2 Master / Slave bridge solution
- -40 to 75°C operating temperature
- Redundant Power Design: 12~48V DC, redundant power with polarity reverse protect function
- IP-30 metal case / Protection
- One box design, Master / Slave selectable via DIP Switch
- Selectable BNC and RJ-11 mode for the data transmission
- Defines Asymmetric (Band Plan 998) and Symmetric band plans for the transmission of Upstream and Downstream signals
- Complies with IEEE 802.3, IEEE 802.3u and IEEE 802.3x standards
- DMT (Discrete Multi-Tone) line coding
- Half Duplex Back Pressure and IEEE 802.3x Full Duplex Pause Frame Flow Control
- Support up to 1536 bytes packet size, 802.1Q VLAN tag transparent
- Integrated address look-up engine, support 2K absolute MAC addresses
- VDSL2 Stand-Alone transceiver for simple bridge modem application
- Selectable Target Band Plan and Target SNR Margin
- Support extensive LED indicators for network diagnostics
- DIN Rail and Wall Mount Design

1.4 Specifications

Product		IVC-2002
Hardware Specification		
Ports	10/100 Base-TX	4 x RJ-45, Auto-Negotiation and Auto-MDI/MDI-X
	VDSL	1 x RJ-11, female Phone Jack 1 x BNC, female connector
DIP Switch		4 position DIP switch
Functionality *1		Master / Slave mode select Selectable BNC and RJ-11 mode Selectable target Band Plan Selectable target SNR mode
Encoding		VDSL-DMT - ITU-T G.997.1 - ITU-T G.993.1 VDSL - ITU-T G.993.2 VDSL2 (Profile 17a Support)
LED Indicators		P1 (Green) P2 (Green) Fault (Green) Master (Green) and Slave (Green) ACT (Green) Sync. (Green)
Cabling	Ethernet	<ul style="list-style-type: none"> • 10Base-T: 2-pair UTP Cat.3, 4, 5 up to 100m (328ft) • 100Base-TX: 2-pair UTP Cat.5, 5e, 6 up to 100m (328ft)
	VDSL (RJ-11)	Twisted-pair telephone wires (AWG24 or better) up to 1.4km
	BNC	50 ohm, RG58A/U, RG58C/U, RG58/U or 75 ohm, RG6 (Distance 2.4km)

Performance *2 (Down Stream / Up Stream)	Asymmetric Mode	
	VDSL (RJ-11)	BNC
	200m -> 99/63Mbps	200m -> 99/65Mbps
	400m -> 91/48Mbps	400m -> 99/64Mbps
	600m -> 71/32Mbps	600m -> 97/59Mbps
	800m -> 53/18Mbps	800m -> 94/51Mbps
	1000m -> 38/8Mbps	1000m -> 84/45Mbps
	1200m -> 33/5Mbps	1200m -> 73/37Mbps
	1400m -> 28/2Mbps	1400m -> 61/28Mbps
		1600m -> 54/20Mbps
	1800m -> 48/13Mbps	
	2000m -> 39/9Mbps	
	2200m -> 35/6Mbps	
	2400m -> 31/4Mbps	
Symmetric Mode		
VDSL (RJ-11)	BNC	
200m -> 91/99Mbps	200m -> 95/99Mbps	
400m -> 74/79Mbps	400m -> 92/97Mbps	
600m -> 54/51Mbps	600m -> 81/82Mbps	
800m -> 38/34Mbps	800m -> 71/70Mbps	
1000m -> 27/21Mbps	1000m -> 60/57Mbps	
1200m -> 24/15Mbps	1200m -> 50/44Mbps	
1400m -> 21/10Mbps	1400m -> 42/33Mbps	
	1600m -> 37/27Mbps	
	1800m -> 29/22Mbps	
	2000m -> 23/21Mbps	
	2200m -> 19/17Mbps	
	2400m -> 19/13Mbps	
Dimensions (W x D x H)	135mm x 87.8mm x 32mm	
Weight	495g	
Power Requirement	12~48V DC, Redundant power with polarity reverse protection function	

Power Consumption / Dissipation	5.64Watts / 19.24BTU
Installation	DIN Rail Kit and Wall Mount Ear
Standard Conformance	
Stability testing	IEC60068-2-32 (Free Fall) IEC60068-2-27 (Shock) IEC60068-2-6 (Vibration)
Operating Temperature	-40 ~ 75°C
Storage Temperature	-40 ~ 80°C
Operating Humidity	10% to 90%, relative humidity, non-condensing
Storage Humidity	10% to 90%, relative humidity, non-condensing
Regulation Compliance	FCC Part 15 Class A, CE
Standards Compliance	IEEE 802.3 10Base-T IEEE 802.3u 100Base-TX IEEE 802.3x Full Duplex Pause frame Flow Control ITU-T <ul style="list-style-type: none"> • G.997.1 • G.993.1 VDSL • G.993.2 VDSL2 (Profile 17a)

*1 BNC and RJ-11 mode must switch to the same position for Master and Slave. Otherwise, it may cause unstable.

*2. The actual data rate will vary on the quality of the copper wire and environment factors.

2. Hardware Description

■ IVC-2002

The IVC-2002 provides 4 RJ-45, 1 RJ-11 and 1 BNC port for network line connection. The 4 RJ-45 ports with two different running speeds – 10Mbps and 100Mbps. It will distinguish the speed of incoming connection automatically.

This section describes the hardware features of the Industrial Ethernet Extender. For easier control of the Industrial Ethernet Extender, familiarize yourself with its display indicators and ports. Front panel illustrations in this chapter display the unit LED indicators. Before connecting any network device to the Industrial Ethernet Extender, read this chapter carefully.

2.1 Front Panel

The units' front panel provides a simple interface monitoring the Industrial Ethernet Extender.

■ IVC-2002 Front Panel



Figure 2-1: IVC-2002 front panel

2.1.1 LED indicators for IVC-2002

The rich diagnostic LEDs on the front panel can provide the operating status of individual port and whole system.

■ System

LED	Color	Function	
P1	Green	Light	indicate the power 1 has power
P2	Green	Light	indicate the power 2 has power
FAULT	Green	Light	indicate the either power 1 or power 2 has no power

■ VDSL / BNC

LED	Color	Function	
ACT	Green	Light	Indicate that the VDSL link is established
		Blink	Indicate that the VDSL link is actively sending or receiving data over that port
Sync	Green	Light	Indicate that the VDSL link is established.
		Fast Blink	Indicate that the VDSL link is at training status (about 10 seconds).
		Slow Blink	Indicate that the VDSL link is at idle status.
Master	Green	Light	Indicate the VDSL Bridge is running at Master mode.
Slave	Green	Light	Indicate the VDSL Bridge is running at Slave mode.

■ 10/100Base-TX Port

LED	Color	Function	
LNK/ACT	Green	Light	Indicate that the port is link up.
		Blink	Indicate that the Extender is actively sending or receiving data over that port.
		Off	Indicate that the port is link down .

2.1.2 MODE DIP Switch

The Industrial Ethernet Extender provides 4 selective transmission modes. By switching the transmission modes, you can obtain a best transmission mode to suit with phone line quality or distance of connectivity. The following is the summary table of transmission setting, bandwidth and distance extensibility tested for AWG 24 (0.5mm) twisted-pair without noise and cross talk.

DIP Switch	DIP-1	DIP-2	DIP-3	DIP-4
Function	Mode	Link Type	Band Plan	SNR
OFF	Master	RJ-11	Symm	9dB
ON (default)	Slave	BNC	Asymm	6dB

- Master / Slave
 - ◆ Master (Central Office) – the Master device mode, usually the Master device will be located at the data center of ISP or enterprise to link to the backbone.
 - ◆ Slave (Customer Premises Equipment) – the Slave device mode, usually the Slave device will be located at branch office, home or remote side as the long reach data receiver. The Slave also can be connected to the PC, IP Camera or Wireless Access Point and etc network devices.



Note

When the Industrial Ethernet Extender operate at Slave mode, the DIP switch 2,3,4 is no function.

- Link Type
 - ◆ BNC mode allows IVC-2002 to connect and data transfer by using BNC cable
 - ◆ RJ-11 mode allows IVC-2002 to connect and data transfer by using Telephone Wire

- Band Plan

- ◆ User can switch the Band Plan either Symmetric or Asymmetric by their own. When Symmetric is selected that provides better upstream performance, when Asymmetric is selected that provides better downstream performance. Refer to table above for details.

- Target SNR (Signal Noise Ratio) Margin

- ◆ When fixed SNR margin is selected, the system will maintain the SNR margin at 9 dB across all usable loop length.



1. By default setting, the four DIP switch at **"ON"** position and operate as **"Slave"**. For operate as **"Master"**, please adjust the DIP 1 switch to **"OFF"** position. Adjust other DIP switch setting to fill different network application demand.
2. Link type: both of IVC-2002 must switch to the same position, otherwise, it may cause unstable. For example, if want to connect both of IVC-2002 through BNC cable, the Master (CO) and Slave (CPE) must switch the DIP-2 at BNC mode.

Please power off the Industrial Ethernet Extender before making any transmission mode adjustment.

2.2 The Upper Panel

The upper panel of the Industrial Ethernet Extender consist one terminal block connector within two DC power inputs. Figure 2-2 shows the upper panel of the Industrial Ethernet Extender.

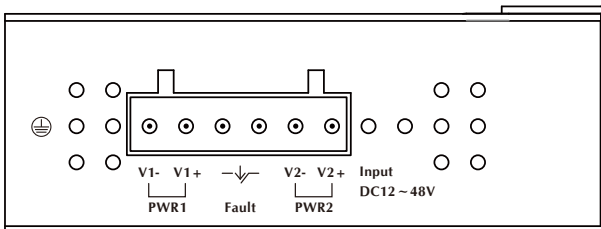

Figure 2-2 Industrial Ethernet Extender upper Panel.

3. Installation

3.1 Install Industrial Ethernet Extender – IVC-2002

The Industrial Ethernet Extender does not require any software configuration. Users can immediately use any feature of this product simply by attached the cables and plug power on. There is some key limitation on the Industrial Ethernet Extender. Please check the following items:

IVC-2002: The device is used for **Point-to-Point** connection only (Master device to Slave device) and has equipped with one RJ-11 and one BNC connectors for VDSL2 port for network link connection.

Phone wire: Depending on the quality of telephone line, the maximum distance of one VDSL segment is 1.4km (4593ft) with AWG 24 telephone wires.

Coaxial: Depending on the quality of coaxial cable, the maximum distance of one VDSL segment is 2.4km (7874ft) with 5C coaxial cable.

The distances will be changed by the quality of telephone wires and coaxial cables.

3.2 IVC-2002 BNC / RJ-11 Proper Connection

PLANET Industrial Ethernet Extender has a DIP switch which can adjust to be Master or Slave mode. Connection of two PLANET Industrial Ethernet Extenders, one must be Master (CO) mode and the other one must be Slave (CPE) mode. Please refer to the following Figure 3-1 chart.



Note

Industrial Ethernet Extender does not allow to connect **BNC** and **RJ-11** at the same time.

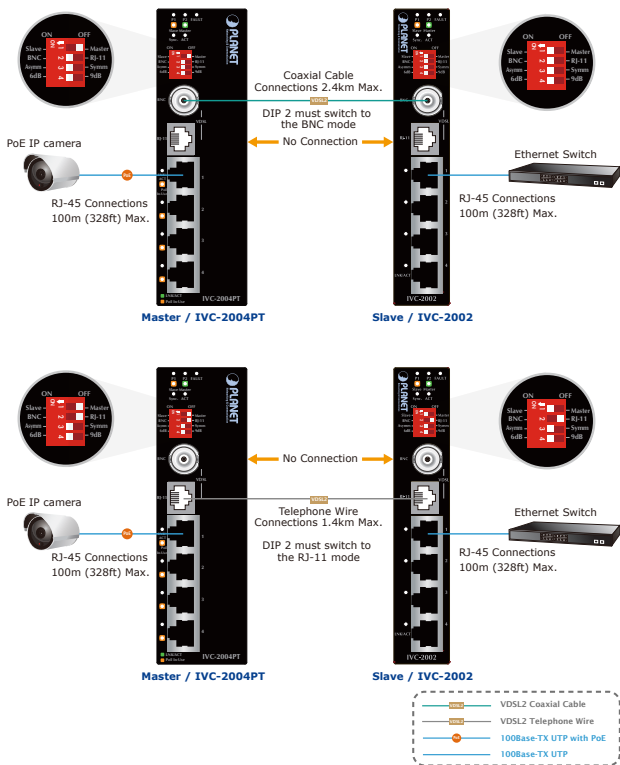

Figure 3-1: Industrial Ethernet Extender BNC and RJ-11 connection chart

3.3 IVC-2002 Application Connection

Two sets of the Industrial Ethernet Extenders could be used to link two local Area networks that are located in different place. Through the normal telephone line or coaxial cable, it could setup a 99/63Mbps (RJ-11) or 99/65Mbps (BNC) asymmetric backbone.

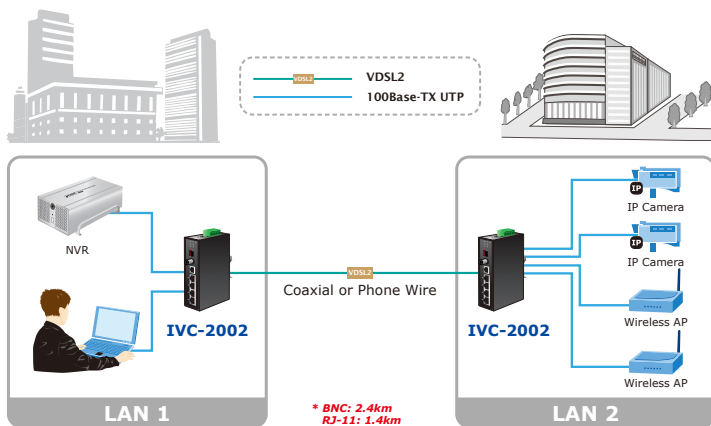
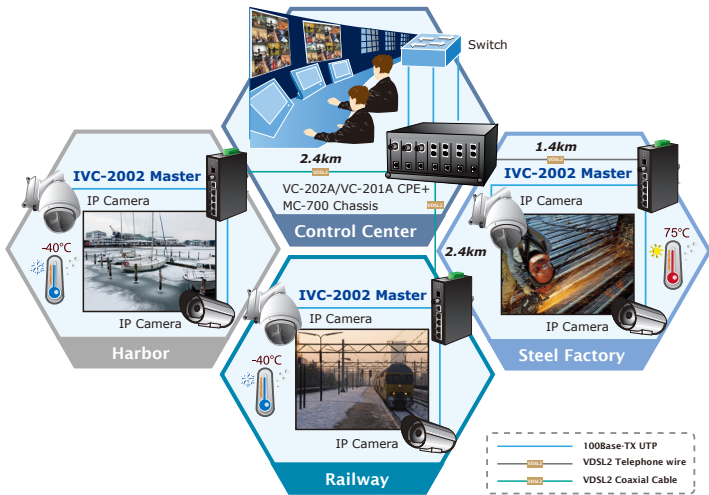

Figure 3-2: IVC-2002 BNC and RJ-11 connection

Advantage of IVC-2002 which it compatibles with PLANET VC-201A and VC-202A. Without spend extra cost to deploy a new local Internet in apartment, hotel, campus and hospitality environment. It can use the original network structure to re-deploy with our latest product PLANET IVC-2002. For example, MC-700, MC-1500, MC-1500R chassis with VC-201A and VC-202A inside and set it as **CPE (Customer Premises Equipment)** which need to be placed in the wiring center (MDF room) and connect it to the telephone line system or coaxial cable system. On the other hand, need to connect an **IVC-2002 extender with Master mode** and connect it to the PLANET Chassis through the telephone lines or coaxial cables.



When deciding where to put the IVC-2002 then you must ensure:

- ◆ It is accessible and cables can be connected easily.
- ◆ Cabling is away from sources of electrical noise such as radios, transmitters and power lines and fluorescent lighting fixtures.
- ◆ Water or moisture can not enter the IVC-2002.
- ◆ Air flow around the unit and through the vents in the side of the case is not restricted (company recommend that you provide a minimum of 25mm inch clearance).

To prolong the operational life of your units:

- ◆ Do not place objects on top of any unit or stack.

3.4 Wiring the Power Inputs

The 6-contact terminal block connector on the top panel of Industrial Ethernet Extender is used for two DC redundant powers input. Please follow the steps below to insert the power wire.

1. Insert positive / negative DC power wires into the contacts 1 and 2 for POWER 1, or 5 and 6 for POWER 2.

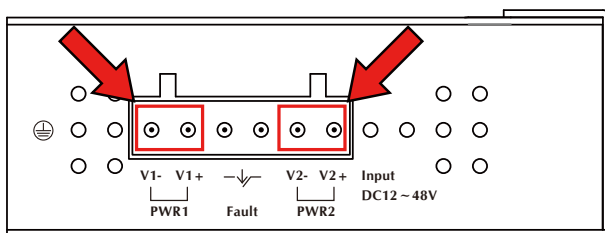

V1- V1+

V2- V2+

2. Tighten the wire-clamp screws for preventing the wires from loosing.

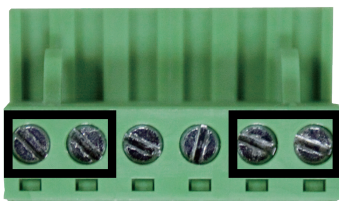

1	2	3	4	5	6
Power 1		Fault		Power 2	
-	+			-	+

3.5 Wiring the Fault Alarm Contact

The fault alarm contacts are in the middle of the terminal block connector as the picture shows below. Inserting the wires, the Industrial Ethernet Extender will detect the fault status of the power failure and then forms an open circuit. The following illustration shows an application example for wiring the fault alarm contacts.

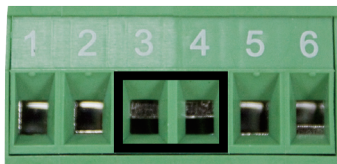

Insert the wires into the fault alarm contacts



Note

1. The wire gauge for the terminal block should be in the range between 12 ~ 24 AWG.
2. Alarm relay circuit accepts up to 30V, max. 3A currents.

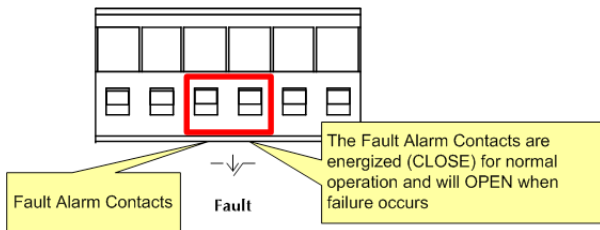

3.6 Mounting Installation

This section describes how to install the Industrial Ethernet Extender and make connection to it. Please read the following topics and perform the procedures in the order being presented.



Note

In the installation steps below, this Manual use IGS-801 (PLANET 8 Port Industrial Gigabit Switch) as the example. However, the steps for PLANET Industrial Switch & Industrial Ethernet Extender are similar.

3.6.1 Install DIN-Rail Mounting

The DIN-Rail is screwed on the Industrial Ethernet Extender when out of factory. Please refer to following figures to hang the Industrial Ethernet Extender on track.



Step 1: Lightly press the button of DIN-Rail into the track.



Step 2: Check the DIN-Rail is tightly on the track.

Step 3: Please refer to following procedures to remove the Industrial Ethernet Extender from the track.



Step 4: Lightly press the button of DIN-Rail for remove it from track.

3.6.2 Wall Mount Plate Mounting

To install the Industrial Ethernet Extender on the wall, please follows the instructions described below.

Step 1: Remove the DIN-Rail from the Industrial Ethernet Extender; loose the screws to remove the DIN-Rail.



Step 2: Place the wall mount plate on the rear panel of the Industrial Ethernet Extender.



- Step 3:** Use the screws to screw the wall mount plate on the Industrial Ethernet Extender.
- Step 4:** Use the hook holes at the corners of the wall mount plate to hang the Industrial Ethernet Extender on the wall.
- Step 5:** To remove the wall mount plate, reverse steps above.

4. Troubleshooting

SYMPTOM:

VDSL LNK LED does not light after wire is connected to the VDSL port.

CHECKPOINT:

1. Verify the length of the wire connected between two IVC-2002 not more than 2.4km (BNC) and 1.4km (RJ-11). Please also try to adjust the DIP switch of IVC-2002 to other SNR mode.
2. Please note you must use one IVC-2002 with Master mode and the other IVC-2002 with Slave mode.

SYMPTOM:

TP LED does not light after cable is connected to the port.

CHECKPOINT:

1. Verify you are using the Cat.5, 5e or 6 cables with RJ-45 connector to connect to the port.
2. If your device (like LAN card) supports Auto-Negotiation, please try to modify at a fixed speed of your device by manually.
3. Check the extender and the connected device's power are "ON".
4. Check the cables are firmly seated in its connectors in the switch and in the associated device.
5. Check the connecting cables are good.
6. Check the power adapter is functional, including the connecting device.

SYMPTOM:

VDSL sometimes will re-chain and unstable.

CHECKPOINT:

1. Verify what connection type of the cable is using, BNC or RJ-11 cable.
2. Check the Master (CO) and Slave (CPE) DIP-2 are switch to the same and correct mode.

5. FAQ

Q1: What Power Input that IVC-2002 used?

A1: 12 ~ 48V DC

Q2: What is VDSL2?

A2: VDSL2 (Very High-Bit-Rate Digital Subscriber Line 2), G.993.2 is the newest and most advanced standard of xDSL broadband wire line communications.

Designed to support the wide deployment of Triple Play services such as voice, data, high definition television (HDTV) and interactive gaming, VDSL2 enable operators and carrier to gradually, flexibly, and cost efficiently upgrade exiting xDSL-infrastructure.

Q3: What is the best distance for IVC-2002?

A3: In order to guarantee the stability and better quality of network, so we would suggest the distance within 1.4 kilometer is the best for RJ-11 Connecting and 2.4 kilometer for BNC Connecting.

Q4: What is the best data rate for IVC-2002?

A4:

Link Type & Distance	RJ-11 (Telephone Wire)		BNC (Coaxial Cable)	
	200m	1400m	200m	2400m
DIP Mode				
Asymmetric	99/63Mbps	28/2Mbps	99/65Mbps	31/4Mbps
Symmetric	91/99Mbps	21/10Mbps	95/99Mbps	19/13Mbps

Q5: Can IVC-2002 compatible with VC-201A / VC-202A?

A5: YES, IVC-2002 (profile 17a) and VC-201A / VC-202A (profile 17a) are base on ITU-T G.993.2 VDSL2 with same Profiles, so far they are compatible with each other.

Q6: What is SNR and what's the effect?

A6: In analog and digital communications, Signal-to-Noise Ratio, often written SNR, is a measure of signal strength relative to background noise. The ratio is usually measured in decibels (dB).

In digital communications, the SNR will probably cause a reduction in data speed because of frequent errors that require the source (transmitting) computer or terminal to resend some packets of data. SNR measures the quality of a transmission channel over a network channel. The greater the ratio, the easier it is to identify and subsequently isolate and eliminate the source of noise.

Generally speaking, the higher SNR value gets better line quality, but lower performance.

Q7: What is band plan and what's the effect?

A7: VDSL2 defines multiple band plans and configuration modes (profiles) to allow asymmetric and symmetric services in the same binder (by designated frequency bands) for the transmission of upstream and downstream signals. User has the ability to select fixed band plan. When Symmetric is selected that provides better downstream performance, when Asymmetric is selected that provides better upstream performance.

EC Declaration of Conformity

For the following equipment:

*Type of Product: Industrial Ethernet Extender (1 BNC / RJ-11 + 4-Port 10/100TX-17a Profile,
-40~75 Degree C)

*Model Number: IVC-2002

* Produced by:

Manufacturer's Name : **Planet Technology Corp.**

Manufacturer's Address: 11F, No 96, Min Chuan Road,
Hsin Tien, Taipei, Taiwan, R.O.C.

is herewith confirmed to comply with the requirements set out in the Council Directive on the Approximation of the Laws of the Member States relating to Electromagnetic Compatibility Directive on (2004/108/EC).

For the evaluation regarding the EMC, the following standards were applied:

Emission	EN 55022	(Class A: 2006)
Harmonic	EN 61000-3-2	(2006)
Flicker	EN 61000-3-3	(1995/A1: 2001/A2:2005)
Immunity	EN 55024	(1998/A1: 2001/A2:2003)
ESD	IEC 61000-4-2	(2001)
RS	IEC 61000-4-3	(2008)
EFT/ Burst	IEC 61000-4-4	(2004)
Surge	IEC 61000-4-5	(2005)
CS	IEC 61000-4-6	(2008)
Magnetic Field	IEC 61000-4-8	(2001)
Voltage Disp	IEC 61000-4-11	(2004)

Responsible for marking this declaration if the:

Manufacturer **Authorized representative established within the EU**

Authorized representative established within the EU (if applicable):

Company Name: **Planet Technology Corp.**

Company Address: **11F, No.96, Min Chuan Road, Hsin Tien, Taipei, Taiwan, R.O.C**

Person responsible for making this declaration

Name, Surname **Kent Kang**

Position / Title : **Product Manager**

Taiwan

Place

15 Oct., 2010

Date



Legal Signature

PLANET TECHNOLOGY CORPORATION

e-mail: sales@planet.com.tw http://www.planet.com.tw

11F, No. 96, Min Chuan Road, Hsin Tien, Taipei, Taiwan, R.O.C. Tel:886-2-2219-9518 Fax:886-2-2219-9528

This page is intentionally left blank