

User's Manual

Z-Wave Smart Energy Meter

▶ HZS-532E-DE/HZS-531A-US



Copyright

Copyright © 2015 by PLANET Technology Corp. All rights reserved. No part of this publication may be reproduced, transmitted, transcribed, stored in a retrieval system, or translated into any language or computer language, in any form or by any means, electronic, mechanical, magnetic, optical, chemical, manual or otherwise, without the prior written permission of PLANET.

PLANET makes no representations or warranties, either expressed or implied, with respect to the contents hereof and specifically disclaims any warranties, merchantability or fitness for any particular purpose. Any software described in this manual is sold or licensed "as is". Should the programs prove defective following their purchase, the buyer (and not PLANET, its distributor, or its dealer) assumes the entire cost of all necessary servicing, repair, and any incidental or consequential damages resulting from any defect in the software. Further, PLANET reserves the right to revise this publication and to make changes from time to time in the contents hereof without obligation to notify any person of such revision or changes.

All brand and product names mentioned in this manual are trademarks and/or registered trademarks of their respective holders.

Federal Communication Commission Interference Statement

This equipment has been tested and found to comply with the limits for a Class B digital device, pursuant to Part 15 of FCC Rules. These limits are designed to provide reasonable protection against harmful interference in a residential installation. This equipment generates, uses, and can radiate radio frequency energy and, if not installed and used in accordance with the instructions, may cause harmful interference to radio communications. However, there is no guarantee that interference will not occur in a particular installation. If this equipment does cause harmful interference to radio or television reception, which can be determined by turning the equipment off and on, the user is encouraged to try to correct the interference by one or more of the following measures:

1. Reorient or relocate the receiving antenna.
2. Increase the separation between the equipment and receiver.
3. Connect the equipment into an outlet on a circuit different from that to which the receiver is connected.
4. Consult the dealer or an experienced radio technician for help.

FCC Caution

To assure continued compliance, use only shielded interface cables when connecting to computer or peripheral devices. Any changes or modifications not expressly approved by the party responsible for compliance could void the user's authority to operate the equipment.

This device complies with Part 15 of the FCC Rules. Operation is subject to the following two conditions: (1) This device may not cause harmful interference, and (2) this device must accept any interference received, including interference that may cause undesired operation.

Federal Communication Commission (FCC) Radiation Exposure Statement

This equipment complies with FCC radiation exposure set forth for an uncontrolled environment. In order to avoid the possibility of exceeding the FCC radio frequency exposure limits, human proximity to the antenna shall not be less than 20 cm (8 inches) during normal operation.

Safety

This equipment is designed with the utmost care for the safety of those who install and use it. However, special attention must be paid to the dangers of electric shock and static electricity when working with electrical equipment. All guidelines of this and of the computer manufacture must therefore be allowed at all times to ensure the safe use of the equipment.

CE Mark Warning

This is a Class B product. In a domestic environment, this product may cause radio interference, in which case the user may be required to take adequate measures.

WEEE Regulation

To avoid the potential effects on the environment and human health as a result of the presence of hazardous substances in electrical and electronic equipment, end users of electrical and electronic equipment should understand the meaning of the crossed-out wheeled bin symbol. Do not dispose of WEEE as unsorted municipal waste and have to collect such WEEE separately.

Revision

User's Manual of PLANET Z-Wave Smart Energy Meter
Model: HZS-532E-DE / HZS-531A-US
Rev: 1.00 (October, 2015)
Part No. EM-HZS-530 Series_v1.0.doc

Table of Contents

Chapter 1. Product Introduction	5
1.1 Package Contents.....	5
1.2 Overview.....	5
1.3 Specifications.....	7
Chapter 2. Hardware Interface.....	8
Chapter 3. Z-Wave Device Setting.....	10
3.1 Configuring Z-Wave Device via Web	10
3.2 Configuring Z-Wave via Smart Phone.....	13
3.3 Configuring Z-Wave via HTS-1000P	19
Appendix A: Troubleshooting & Frequently Asked Questions	28

Chapter 1. Product Introduction

1.1 Package Contents

The package should contain the following:

- Energy Meter x 1
- Quick Installation Guide x 1



Note

If any of the above items are missing, please contact your seller immediately.

1.2 Overview

Home Automation and Smart Home Control

The HZS (Z-Wave Sensing Device) series of PLANET Home Automation product family, based on Z-Wave technology, provides the advanced security system that protects your home and family 24/7. Easy operation and flexible configuration are the attractive features of our system; the simple one-touch button lets you program your regular settings according to your preference and operation mode. Worked with PLANET HAC-1000 Z-Wave Home Automation Control Gateway, you get the all-round and reliable home security services that we offer. Our full range of product lines ensure that you get all the devices you need for your home security system.



Energy and Cost Saving on Every Room

PLANET HZS-530 series is a Z-Wave Smart Energy Meter that checks the current energy consumption in your home within the configuration interface of the HAC-1000. You can also manage these energy-saving devices such as power meter switches, power switches and dimmer switches to help you reduce energy consumption and thus save expenses on utilities.

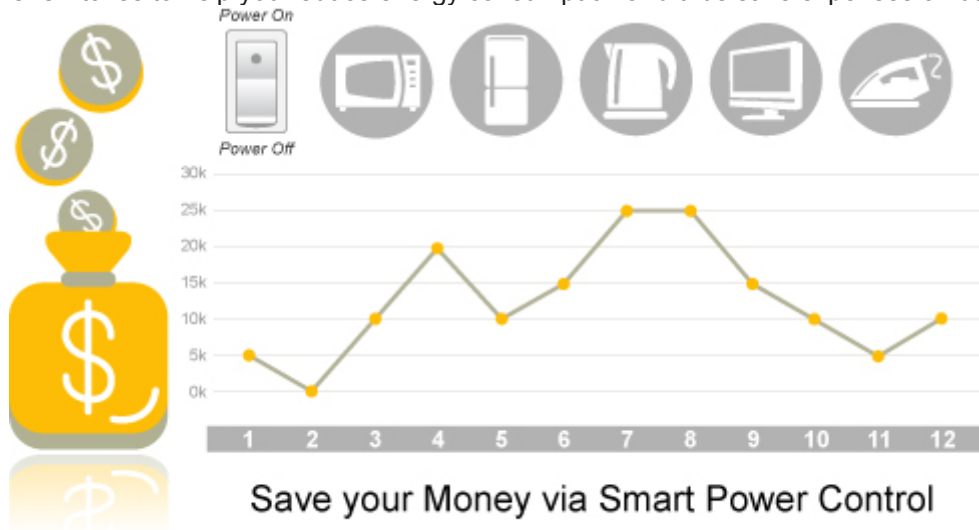

Scheduled Power On/Off

The HZS-530 series Energy Meter allows you to pre-define a power schedule for home devices via the HAC-1000 Control Gateway. It alerts users to an upcoming shutdown, and then waits a predefined amount of time to allow users to finish their work and sign off. For example, you can define a schedule that would shut down your home device on Friday night, and start it again Monday morning.

Getting Started is as Easy as 1-2-3

1. Via the Cloud Home App (including Home Automation Controller Pad and Control Gateway): Press **Inclusion/Exclusion** to include/exclude Z-Wave device.
2. On the Z-Wave device: Press the **Pair** button to establish a connection with the control gateway.
3. Users can enjoy and manage Z-Wave network right away.



Overload Protection

The HZS-530 series Energy Meter is a miniature device that allows you to control the amount of electricity consumed. If the current exceeds 10 amps, the circuit breaker will open up, cutting off any more current flow. Furthermore, the HZS-532E-DE, an ETSI compliant product in the HZS-530 series, could inform you about the current load of the connected appliances by changing in color of its built-in LED.

1.3 Specifications

Product	HZS-531A-US	HZS-532E-DE
Hardware and Network		
Z-Wave Frequency	America: 908.42MHz	Europe: 868.42MHz
LED Indicators	Power On/Off: red/green Z-Wave RF transfer/receive: red/green (flash) Energy level: green/orange/red	
Buttons	1 x Power On/Off button (Either control manually or remotely via the control gateway)	
Load	110V, 10A, 1100W (resistive) 220V, 10A, 2200W (resistive)	
Operating Range	Up to 30 meters in open space	
Installation	Plug connection for indoor use	
General		
Power Requirements	AC 100V~230V	
Operating Temperature	15 ~ 60 degrees C	
Operating Humidity	10 ~ 90% (non-condensing)	
Weight	156g	126g
Dimensions	100 x 62 x 38 mm (W x D x H)	61 x 58 mm (Φ x L)
Emission	CE, FCC	

Chapter 2. Hardware Interface

Model	HVS-531A-US
Dimensions (W x D x H)	100 x 62 x 38 mm
Weight	156g (gross weight)

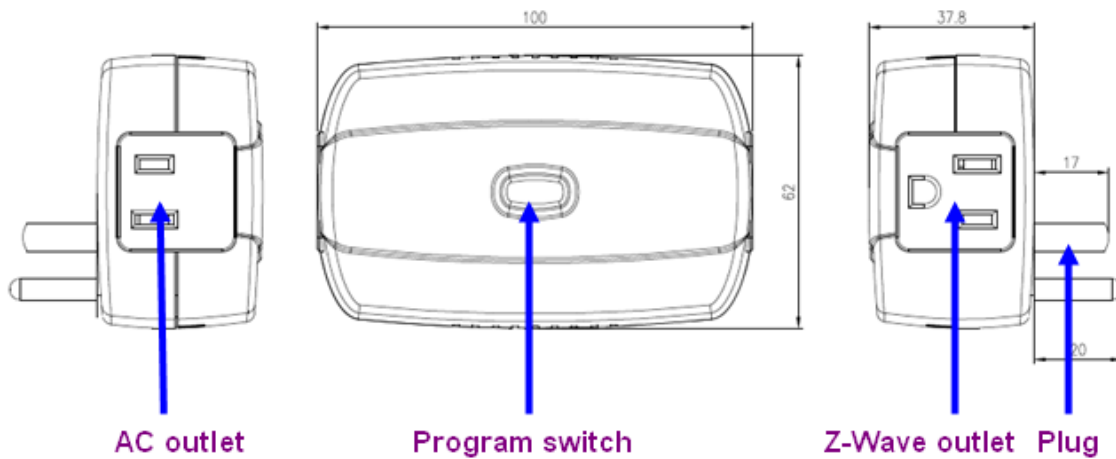

Interface	Description
AC outlet	Connect a device to power outlet to supply power to it.
Program switch	1) Press to include or exclude a Z-Wave network. 2) Switch Power on and off.
Z-Wave outlet	This outlet is used to plug in the device you wish to monitor, such as a lamp. Do not exceed the loading of wattage more than 10A when connecting to an electronic appliance.
Plug	Plug the Energy Meter into any available wall outlet.

Model	HZS-532E-DE
Dimensions (Φ x L)	61 x 58 mm
Weight	126g (gross weight)

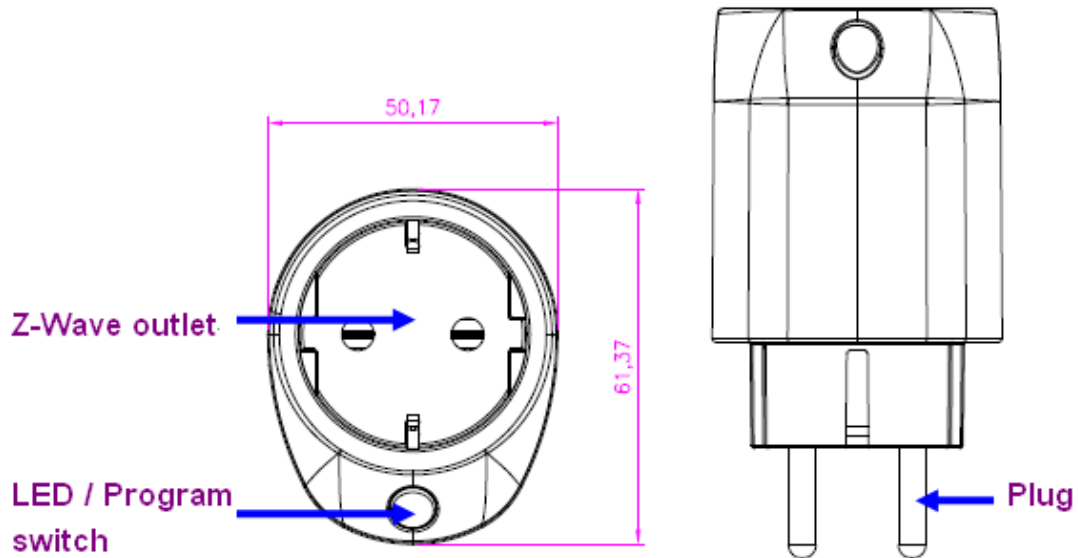

Interface	Description								
LED	Power On/Off: Red/Green Z-Wave RF transfer/receive: Red/Green (Flash) Energy level: Green/Orange/Red <table border="1"> <thead> <tr> <th>Color</th> <th>Current</th> </tr> </thead> <tbody> <tr> <td>Green</td> <td>0 ~ 3 AMP</td> </tr> <tr> <td>Orange</td> <td>3 ~ 7 AMP</td> </tr> <tr> <td>Red</td> <td>7 ~ 10 AMP</td> </tr> </tbody> </table>	Color	Current	Green	0 ~ 3 AMP	Orange	3 ~ 7 AMP	Red	7 ~ 10 AMP
Color	Current								
Green	0 ~ 3 AMP								
Orange	3 ~ 7 AMP								
Red	7 ~ 10 AMP								
Program switch	1) Press to include or exclude a Z-Wave network. 2) Switch Power on and off.								
Z-Wave outlet	This outlet is used to plug in the device you wish to monitor, such as a lamp. Do not exceed the loading of wattage more than 10A when connecting to an electronic appliance.								
Plug	Plug the Energy Meter into any available wall outlet.								

Chapter 3. Z-Wave Device Setting

3.1 Configuring Z-Wave Device via Web

Please refer to the following steps to add Z-Wave device via web.

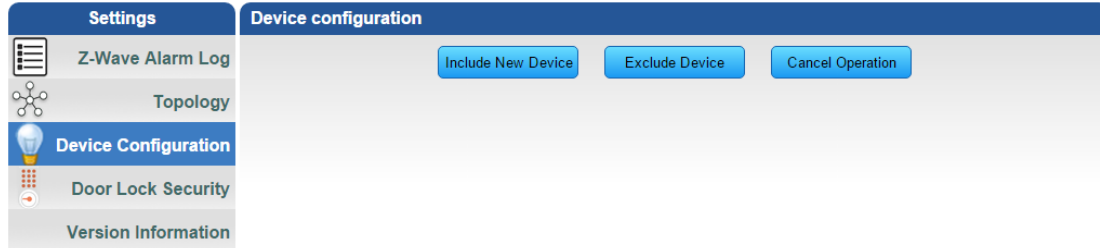

Step 1. Include a Z-Wave device via web.

- a) Go to "Z-Wave" and click "Device Configuration".
- b) Click "Include New Device" and the screen will appear with "Add Device: Waiting for a user action."
- c) Press the program switch button **3 times within 2 seconds** on the Z-Wave device to connect.

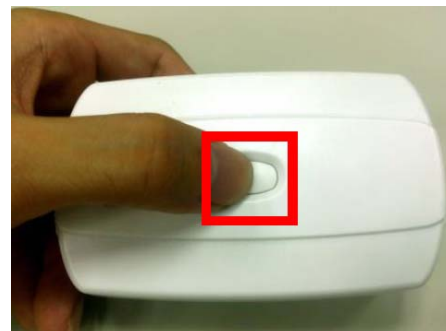

- d) If your device has successfully been added, it will show "Add Device: Command has been completed successfully".

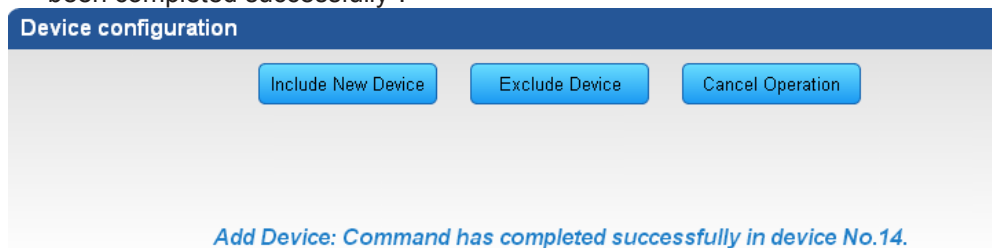

If the device didn't add successfully, please place the device next to the gateway and try again.

Step 2. Set up the location and room for Z-Wave device via web.

a. Create rooms in your environment.

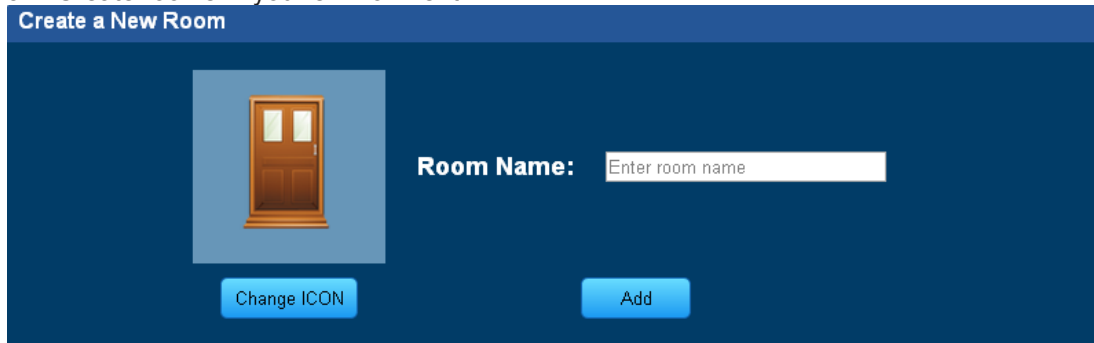

The screenshot shows a web interface titled "Create a New Room". On the left, there is a placeholder image of a wooden door. Below it is a "Change ICON" button. To the right of the image, the text "Room Name:" is followed by a text input field containing the placeholder text "Enter room name". Below the input field is an "Add" button.

b. Edit device.

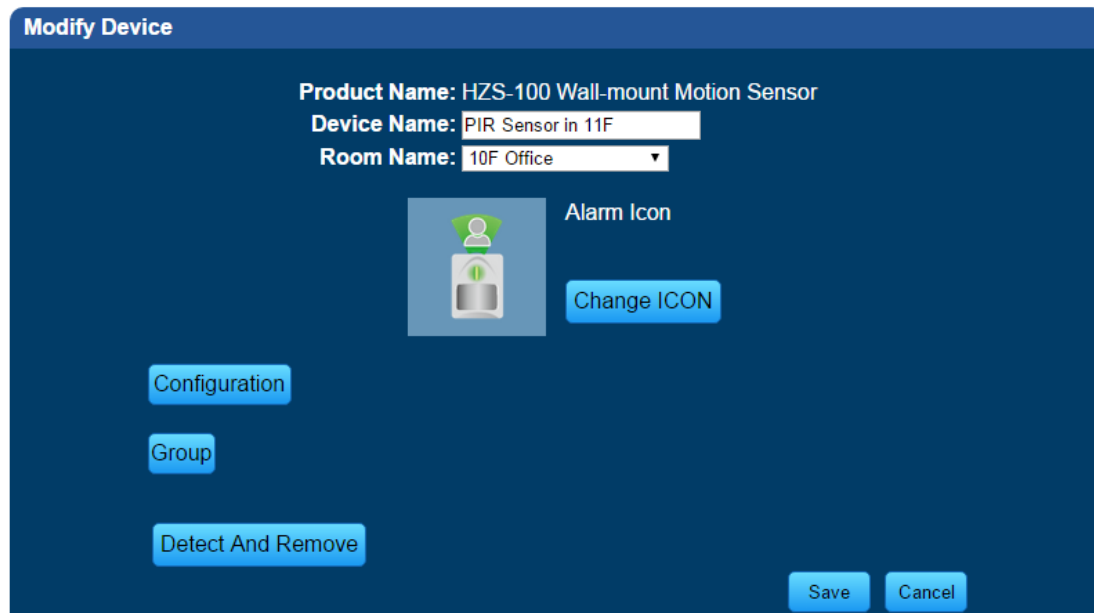

The screenshot shows a web interface titled "Modify Device". At the top, it displays "Product Name: HZZS-100 Wall-mount Motion Sensor". Below this, there are three fields: "Device Name:" with the value "PIR Sensor in 11F", "Room Name:" with a dropdown menu showing "10F Office", and "Alarm Icon" with a placeholder image of a sensor. Below the alarm icon is a "Change ICON" button. At the bottom, there are four buttons: "Configuration", "Group", "Detect And Remove", "Save", and "Cancel".

Step 3. Create a scene via web.

a. Click "Create Scene" and name new scene.

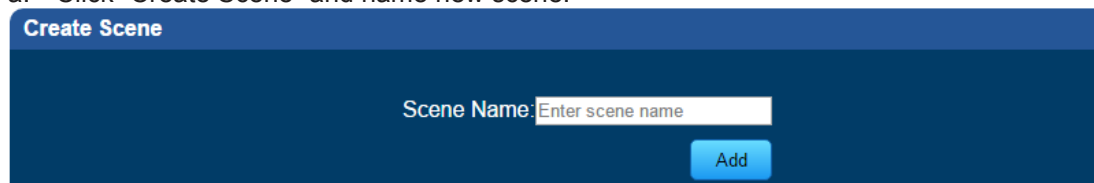

The screenshot shows a web interface titled "Create Scene". It features a "Scene Name:" label followed by a text input field containing the placeholder text "Enter scene name". Below the input field is an "Add" button.

b. Select a device from this scene.

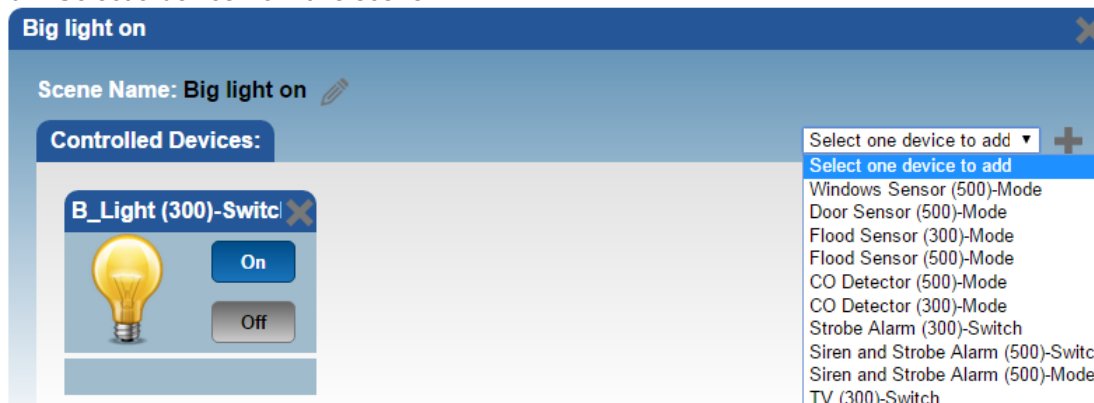

The screenshot shows a web interface titled "Big light on" for editing a scene. At the top, it displays "Scene Name: Big light on" with an edit icon. Below this is a "Controlled Devices:" section. On the left, there is a device card for "B_Light (300)-Switch" with a lightbulb icon and "On" and "Off" buttons. On the right, there is a dropdown menu titled "Select one device to add" with a plus sign. The dropdown menu is open, showing a list of devices: Windows Sensor (500)-Mode, Door Sensor (500)-Mode, Flood Sensor (300)-Mode, Flood Sensor (500)-Mode, CO Detector (500)-Mode, CO Detector (300)-Mode, Strobe Alarm (300)-Switch, Siren and Strobe Alarm (500)-Switch, Siren and Strobe Alarm (500)-Mode, and TV (300)-Switch.

- c. Select ON or OFF from this scene.

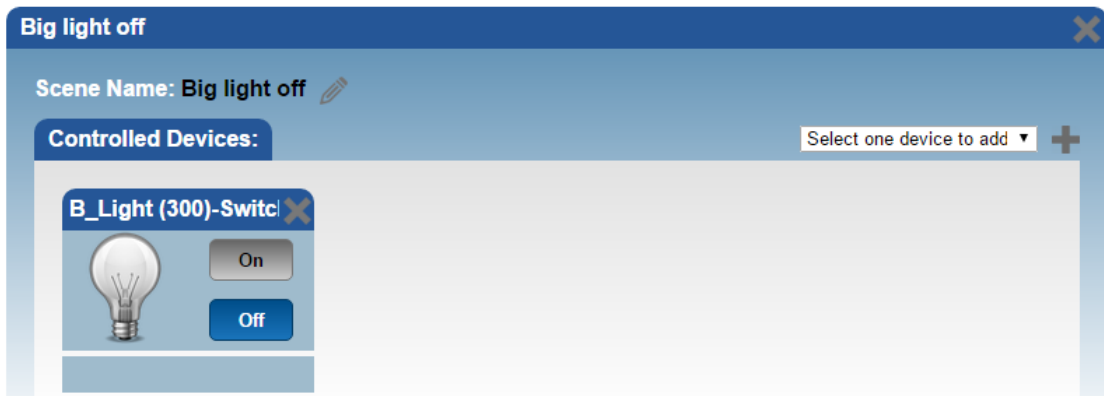

- d. You can click "RUN" to run this scene.

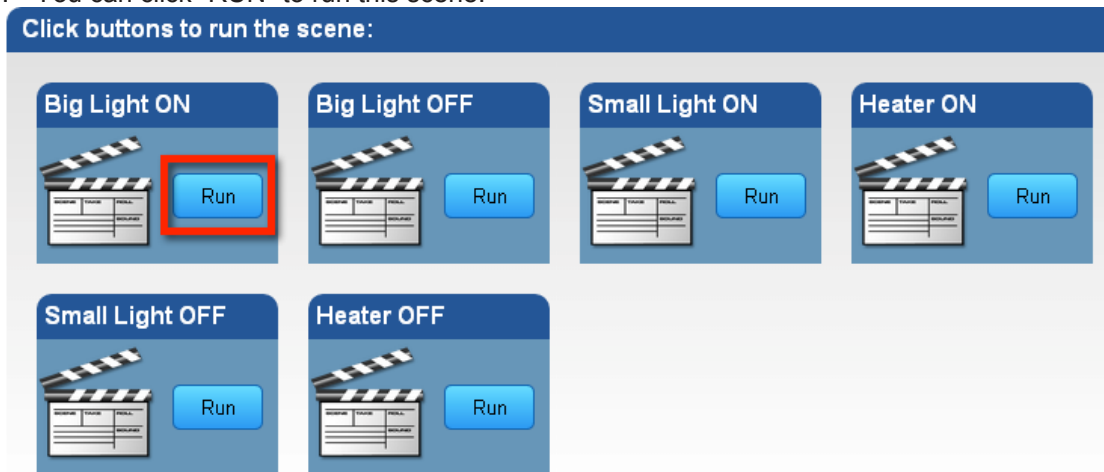

Step 4. Create trigger via web.

- Click "Create a Trigger" and name new trigger.
- Select a Z-Wave device for this trigger.
- Select when it triggers, it will alarm or bypass.
- Select when it triggers, it will run which scene.

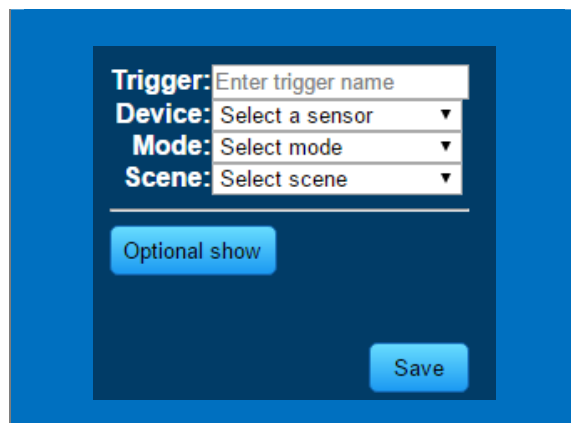

After entering the time selected for the scene to trigger, tick “Save and send alarm notification”. Tick “Active” to enable this trigger.

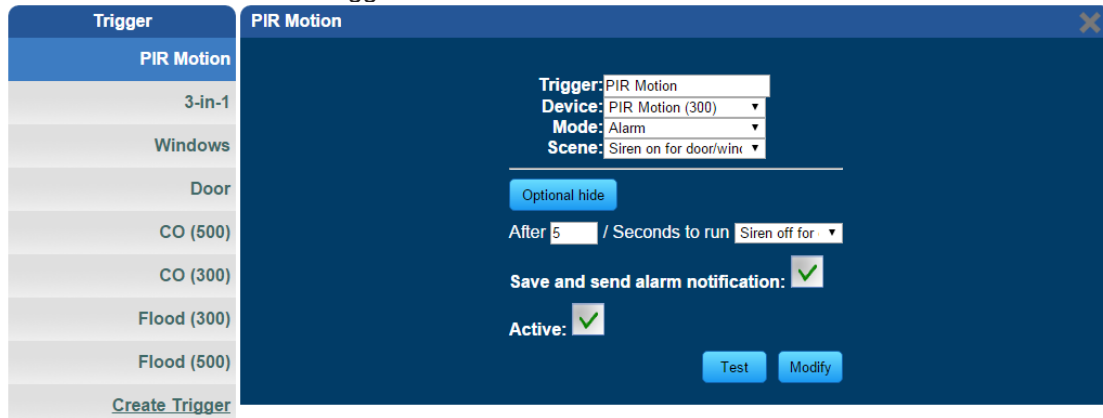

3.2 Configuring Z-Wave via Smart Phone

The HAC-1100 can be used on iOS and Android operating system. Cloud Home can be downloaded at Google Play store or app store.

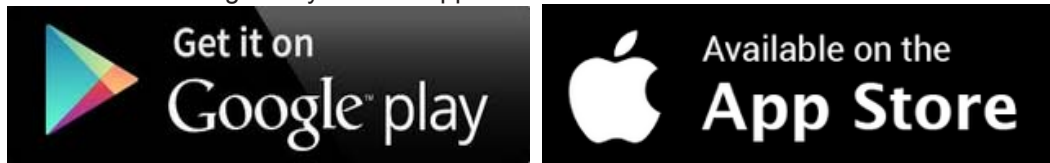

Please refer to the following steps to install Cloud Home app and add Z-Wave device via smart phone.

Step 1. Include a Z-Wave device via smart phone (Android/iOS).

a. Register a user account.

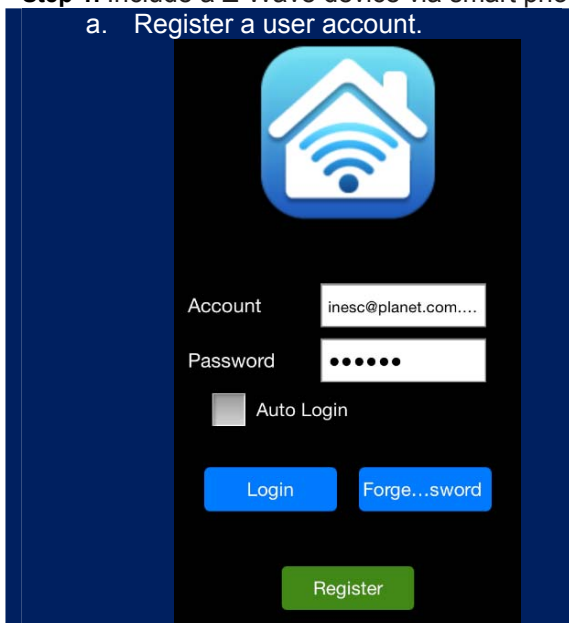

b. Setting



c. Inclusion/Exclusion

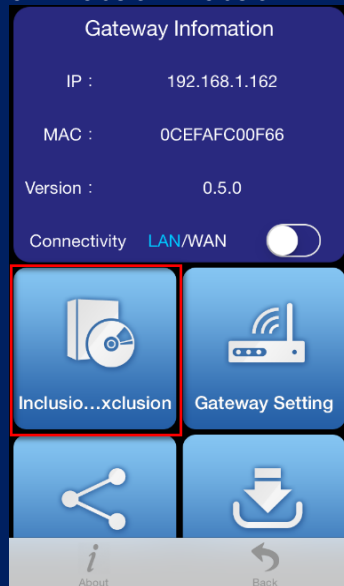

d. Click Inclusion to add device.

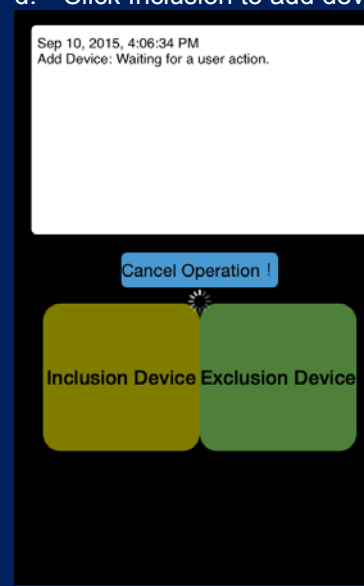

e. e. Press the program switch button **3 times within 2 seconds** on the Z-Wave device to connect.



Step 2. Set up the location and room for Z-Wave device.

a. Create rooms in your environment.

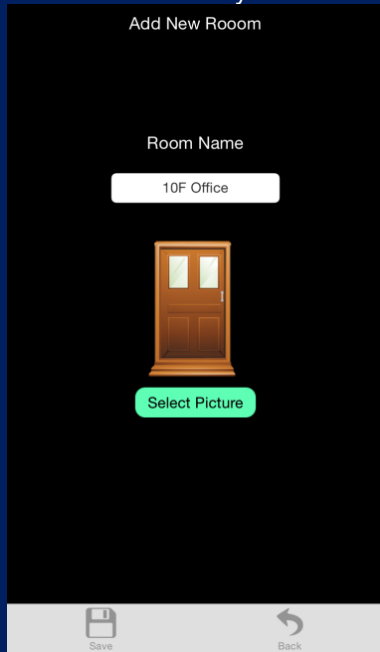

b. Click "No Room" and will show the device. And place the new devices in a room.

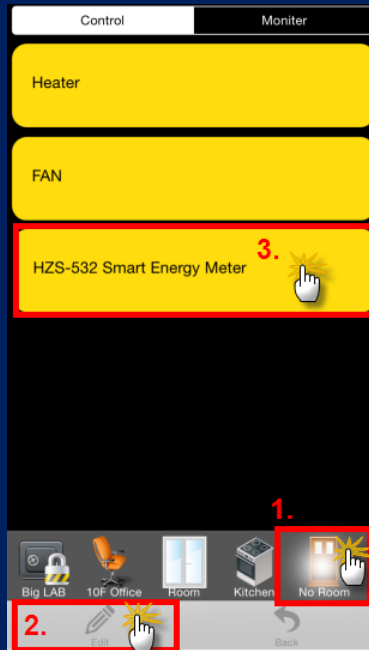

c. Select "Name" to name this device and select "Location" to place this device in the room that you created.

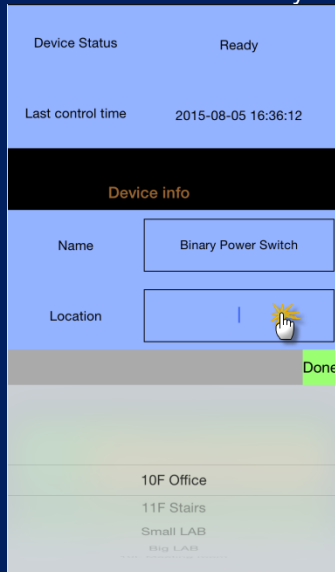

d. Select Picture for your Z-Wave device.

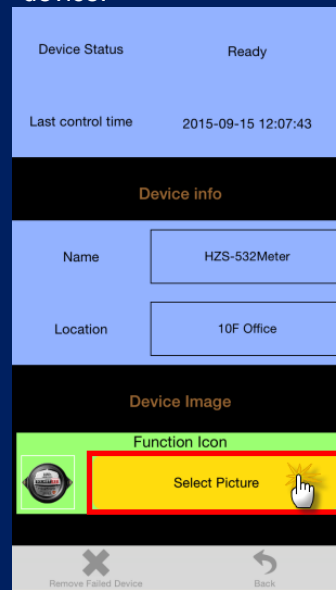

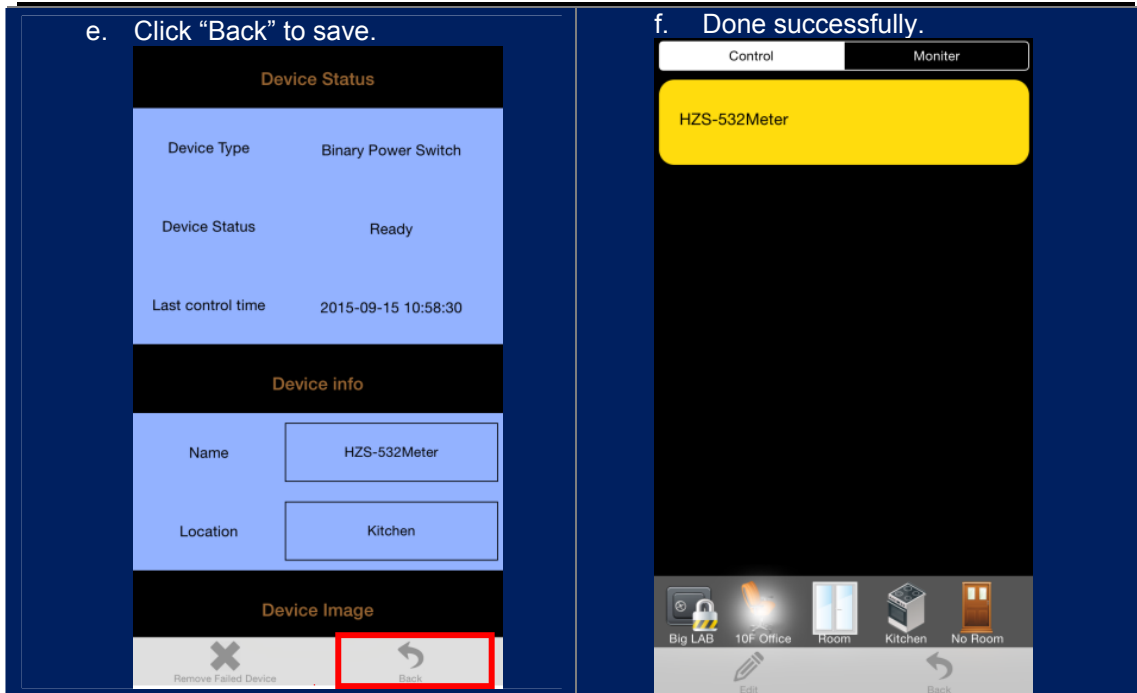

Step 3. Create a scene via smart phone.

a. Click "Add" and name a new scene.



b. Click "Add" to add a Z-Wave device.



c. Select a Z-Wave device.

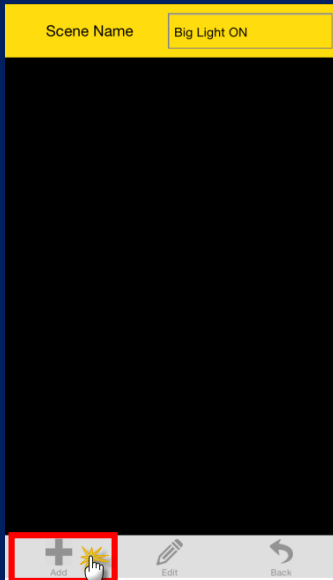

d. Click ON or OFF for the device you select.



e. Click "Back" to save.

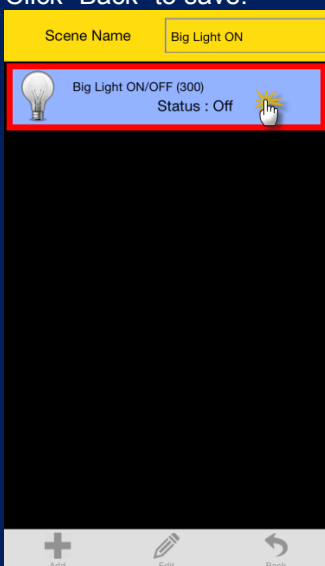

f. Done successfully.



Step 4. Create Trigger via smart phone.

a. Click "Add".



b. Name this new Trigger.



c. Select the Z-Wave device and click next.

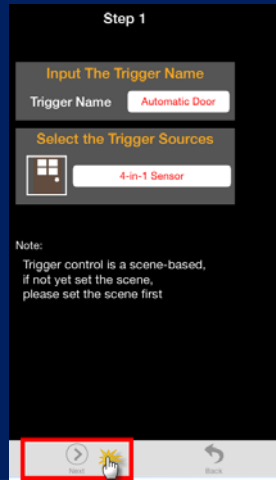

d. Select a mode for a Z-Wave device.

e. Select a scene.

f. Select the time for the trigger and which scene to run.

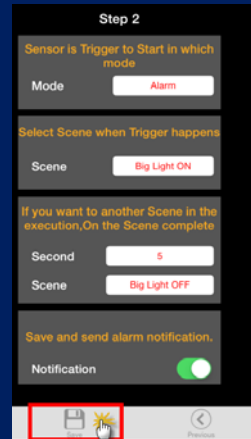

g. Done successfully.

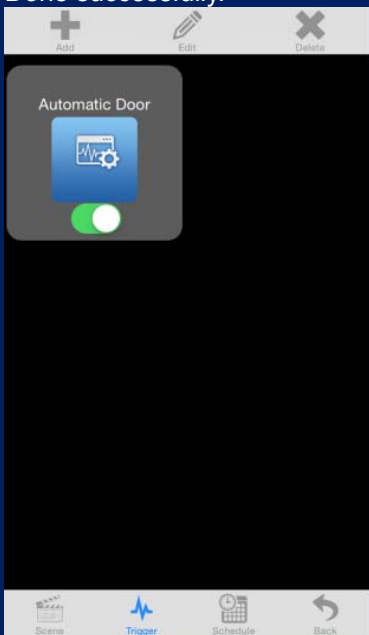

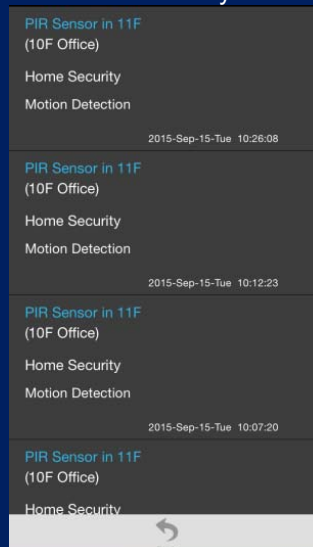

h. If you enable Save and send alarm notification, when it triggers, it will have a log. You can check this in Notification History.

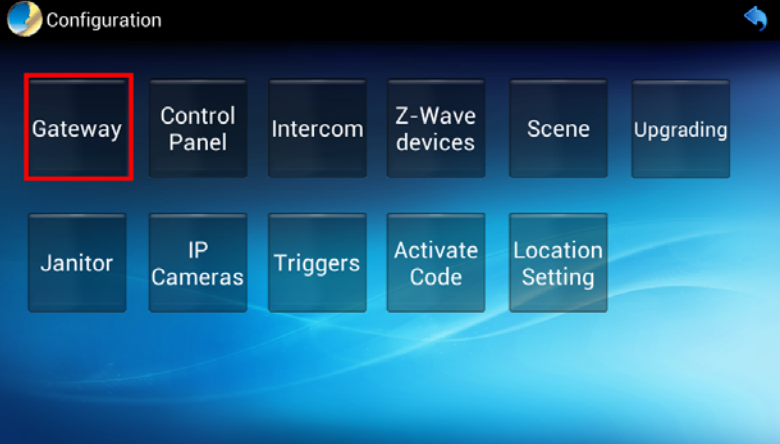
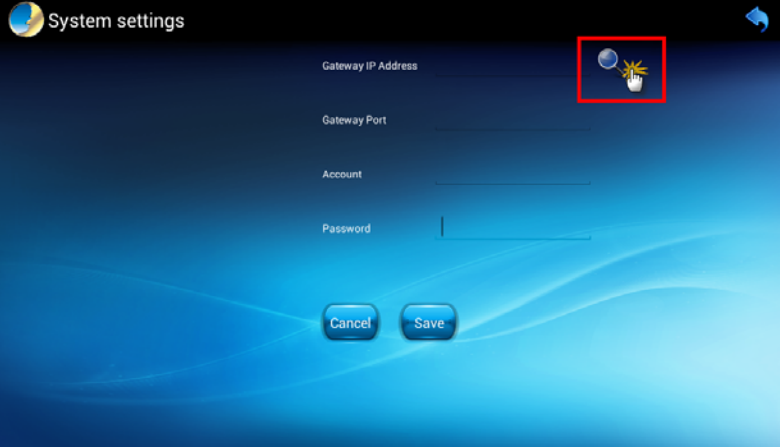

3.3 Configuring Z-Wave via HTS-1000P

Step 1. Fill out the IP of control gateway to connect with gateway.

<p>Click the "Gateway" button.</p>	 <p>The screenshot shows a 'Configuration' screen with several menu items: Gateway, Control Panel, Intercom, Z-Wave devices, Scene, Upgrading, Janitor, IP Cameras, Triggers, Activate Code, and Location Setting. The 'Gateway' button is highlighted with a red rectangular box.</p>
<p>Click the magnifying glass to search the IP of gateway.</p>	 <p>The screenshot shows a 'System settings' screen with fields for Gateway IP Address, Gateway Port, Account, and Password. A magnifying glass icon is highlighted with a red rectangular box.</p>
<p>Control pad found an IP of gateway. Click the IP to join.</p>	 <p>The screenshot shows a 'System settings' screen with a search result for IP 192.168.1.163. The IP address and its associated MAC address (ABF7E0C01397) are displayed, and the IP address is highlighted with a red rectangular box.</p>

The default gateway port is 5000, and user name and password are both **admin**.



Step 2. Include a Z-Wave device via HTS-1000P.

Click the “Z-Wave devices” button to add Z-Wave devices to gateway.



Click the “Include New Device” button to add Z-Wave device.

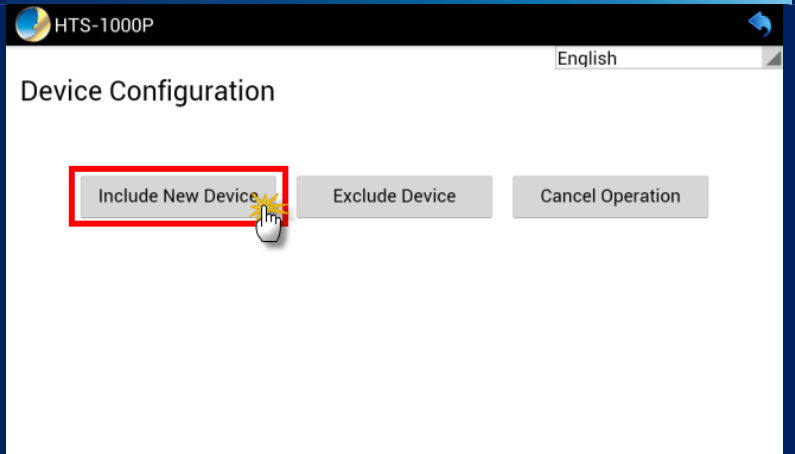

When you see the message “Waiting for user action”, you can press the match button on Z-Wave devices.

Press the program switch button **3 times within 2 seconds** on the Z-Wave device to connect.

If a device is added successfully, it will show the message: “Command has completed successfully in device No. XX”.

Click the “Exclude Device” button to exclude Z-Wave device.

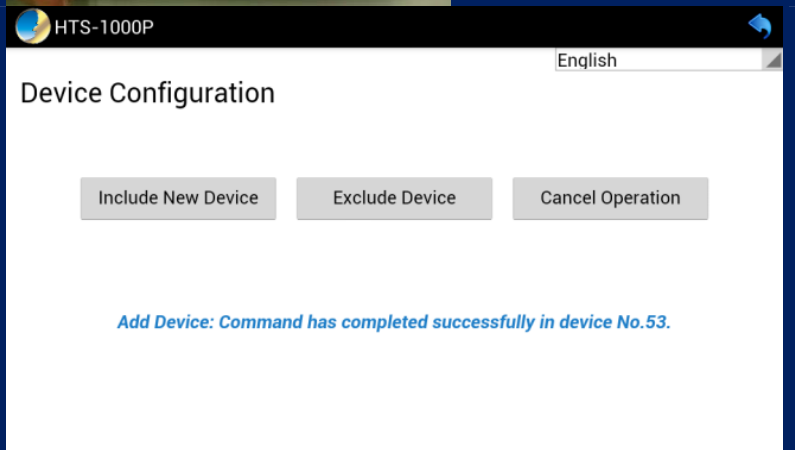
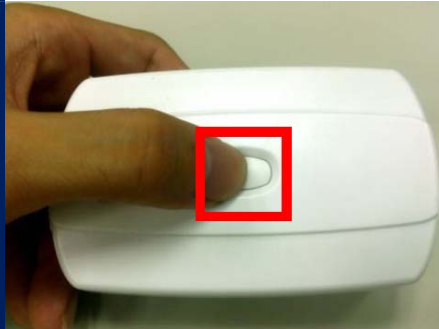
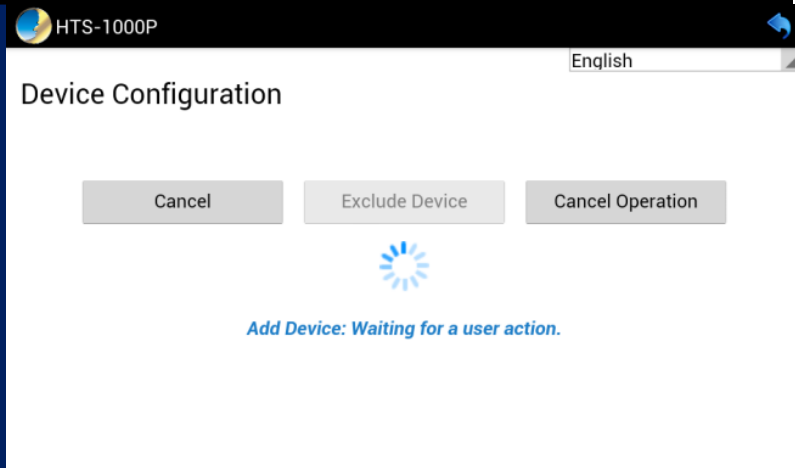

When you see the message “Waiting for user action”, you can press the match button on Z-Wave devices to exclude device.

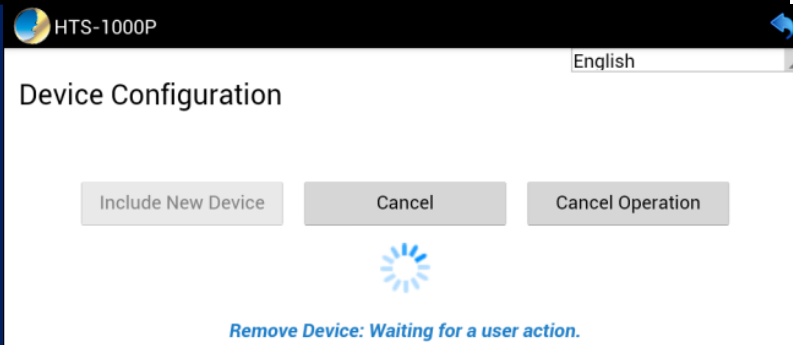

Step 3. After including Z-Wave devices in gateway, you can create different scenes with this function. You can set scenes to control your devices in **Scene** mode.

Click the “Scene” button.

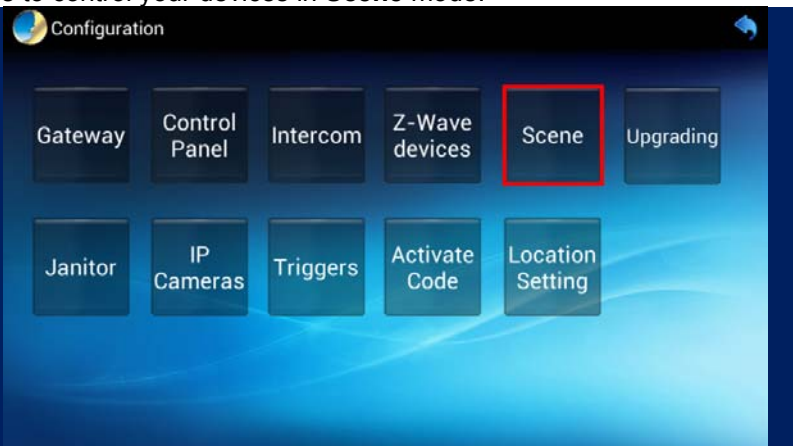

Click “Create Scene” and name the new scene.

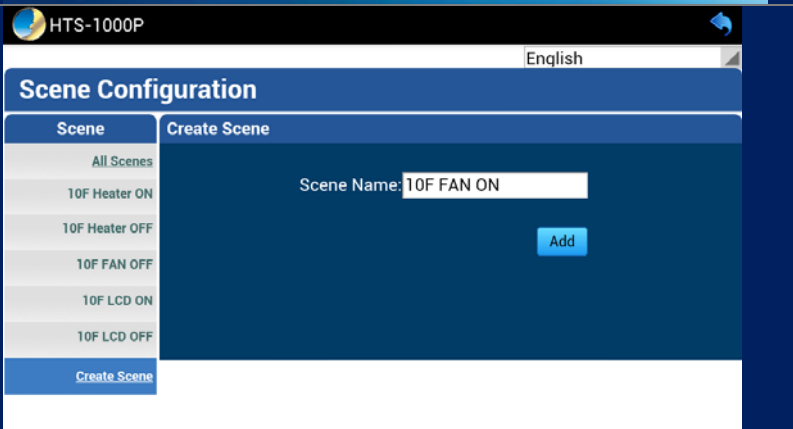

Select one device to add to the device list.

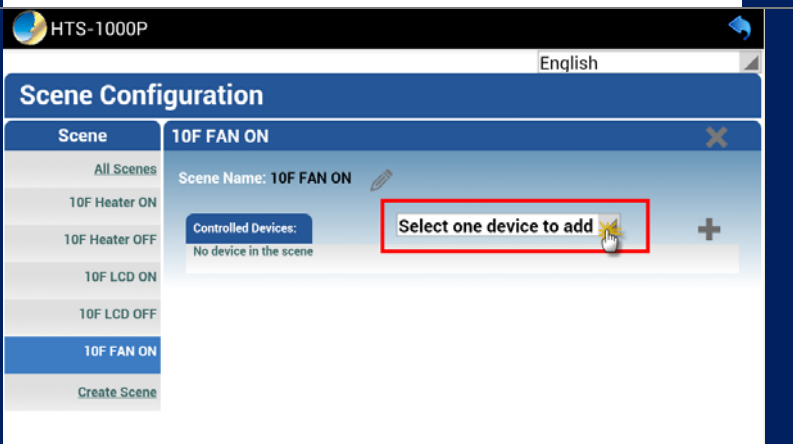

<p>Select one device.</p>	
<p>Click the "Plus" button to add device.</p>	
<p>Select the status of device (ON or OFF).</p>	
<p>Click "All Scenes" to check the scene.</p>	

Step 4. In the Trigger mode, the trigger time is set. An alarm notification is sent via sensor. If a sensor is not installed, this step can be skipped.

Click the "Trigger" button.



The screenshot shows a 'Configuration' screen with several menu items: Gateway, Control Panel, Intercom, Z-Wave devices, Scene, Upgrading, Janitor, IP Cameras, Triggers (highlighted with a red box), Activate Code, and Location Setting.

Click "Create Trigger".
Trigger: Name this trigger.

Device: Select a Z-Wave device.

Mode: Select "Arm" to enable alarm.

Scene: When PIR Sensor is triggered, the Fan will turn on.

Optional: After triggering for 5 seconds, the Fan will turn off by itself.

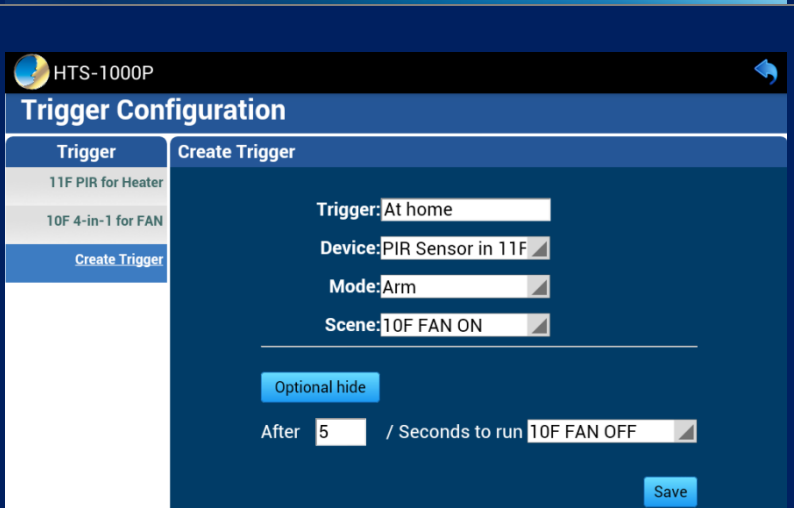

The screenshot shows the 'Trigger Configuration' screen for HTS-1000P. It has a table on the left with columns 'Trigger' and 'Create Trigger'. The table lists '11F PIR for Heater' and '10F 4-in-1 for FAN'. The 'Create Trigger' column is active, showing a form with the following fields: Trigger: At home, Device: PIR Sensor in 11F, Mode: Arm, Scene: 10F FAN ON. Below the form, there is an 'Optional hide' button and a field 'After 5 / Seconds to run 10F FAN OFF'. A 'Save' button is at the bottom right.

Switch to "AWAY" to enable monitoring mode.

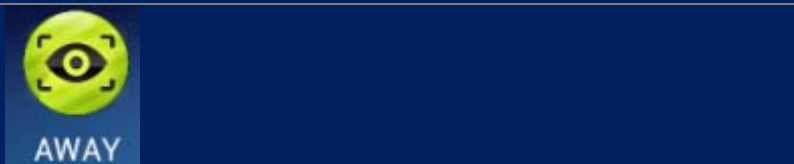

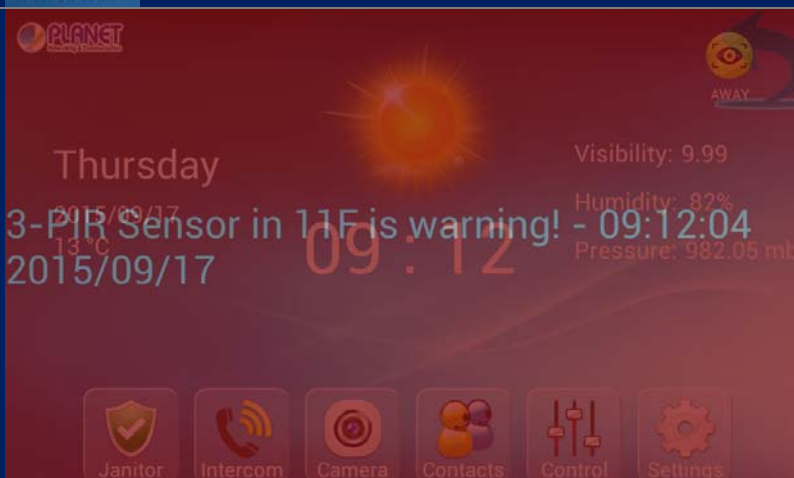

The screenshot shows a yellow eye icon with a green outline, representing the 'AWAY' monitoring mode.

When one of Z-Wave devices is triggered, control pad will alarm.

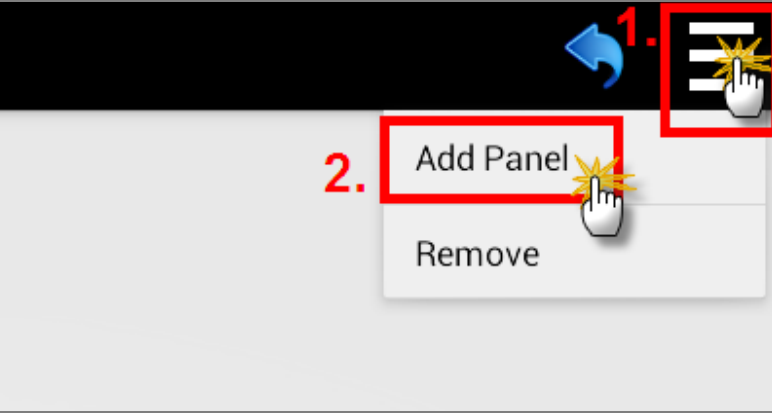

The screenshot shows the main control pad interface. At the top, it says 'Thursday' and '2015/09/17'. A large red notification reads '3-PIR Sensor in 11F is warning! - 09:12:04'. Below the notification, it shows '2015/09/17' and '13°C'. On the right, weather information is displayed: 'Visibility: 9.99', 'Humidity: 82%', and 'Pressure: 982.05 mb'. At the bottom, there is a row of icons for Janitor, Intercom, Camera, Contacts, Control, and Settings. The 'AWAY' mode icon is visible in the top right corner.

Step 5. After configuring this part, you can control Z-Wave devices and scenes via control pad.

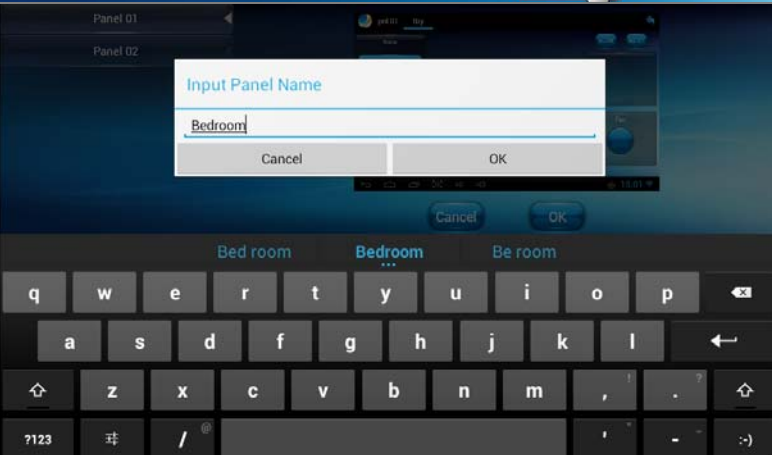
<p>Click the "Control Panel" button.</p>	
<p>Click the three-line button on the upper right corner and click "Add Panel".</p>	
<p>There are two types of panel that you can choose from.</p>	
<p>Name the panel.</p>	

Click and hold two seconds to select the device or scene.



Click on the device field.

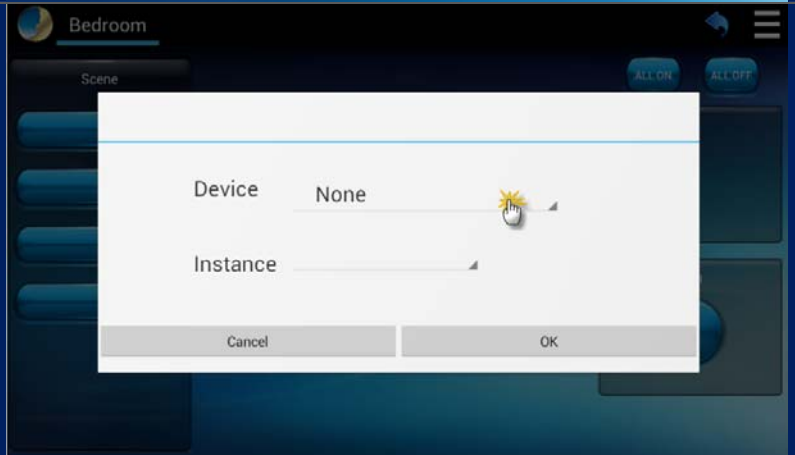

Select a device.



Go back to the main page and click the "Control" button.





Appendix A: Troubleshooting & Frequently Asked Questions

Features	
This difference between Z-Wave and ZigBee	<ul style="list-style-type: none"> The frequency is different between Z-Wave and ZigBee. ZigBee is 2.4GHz and Z-Wave is about 900MHz. The outdoor distance is different. ZigBee is 10~75 meters and Z-Wave is about 30 meters.
Z-Wave Device Installation	
How to reset the HZS-530 Series	Press the Program Switch to power on (plug-in) and hold for 5 seconds before releasing the switch. Only use this procedure when the primary controller is lost or otherwise inoperable.
Repeater Function	You could install the HZS-530 Series to extend the frequency range of Z-Wave. The Energy Meter can act as a signal repeater to enhance the Z-Wave wireless communication range. For example, the HAC-1000 (Control Gateway) is installed on the second floor to control over the HZS-300 (4-in-1 Sensor) installed on the first floor, but the Z-Wave frequency is weak. Thus, HZS-530 Series can be installed in between the second floor and the first floor to solve the problem.
Overload Protection	If load is more than 10.5A for all others, then relay will automatically cut off. To restore the relay, please power off and power on the device again.
How to view the energy consumption report	<ol style="list-style-type: none"> 1) You could install Cloud Home App with PLANET HAC-1000, and check the report about the voltage, current, wattage and total KWh usage. 2) Go to the report of the HAC-1000 and check the voltage, current, wattage and total KWh usage.